

PRODUCT DATASHEET

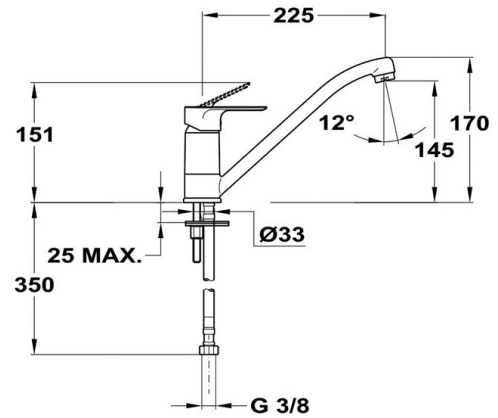

Trend Plus | Sink mixer

- Swivel low spout
- 225 mm spout
- Anti-scale aerator
- Size of aerator: M24x1
- 40 mm cartridge
- 3/8" flexible inlet pipe

REF.

[152-1551-02](#)

Other datas

Code	EAN	Master box	Palette	Weight
152-1551-02	5995841031120	1 pcs	96 pcs	1,385 kg